

DELFIN SRL - Società Unipersonale

Società soggetta a direzione e coordinamento da parte della Delfin Holding S.r.l.

📍 STRADA DELLA MERLA, 49/A
10036 SETTIMO T.SE (TO) ITALY

☎ T + 39 011 800 55 00
F + 39 011 800 55 06

✉ DELFIN@DELFINVACUUMS.IT

🌐 DELFINVACUUMS.COM

🔍 C.C.I.A.A. TO 829720
Tribunale TORINO 24/96
CAP. SOC. 210.000,00 I.V.
Sede Legale C.so Venezia, 63
10147 TORINO
C.F./P.IVA 06998930017

Equipment classification: Industrial vacuum cleaners



MTL202DS



MTL202DSLP



*Operator's and maintenance manual
Original and official manual
Rev.17/12/2019*

Read this manual carefully before using the vacuum cleaner

**AZIENDA CON SISTEMA
DI GESTIONE QUALITÀ
CERTIFICATO DA DNV
= ISO 9001 =**



This manual provides all the information needed to use and service your vacuum cleaner. Good operation and durability depend on proper maintenance and careful use.

Before leaving the factory, this particular model has undergone stringent tests to ensure utmost reliability. Always check however to make sure the vacuum cleaner has not been damaged during transport in such a way as to affect operation and safety.

This manual should be considered an integral part of the vacuum cleaner and must be kept together with the unit until this is scrapped. In case of loss of or damage to the manual, ask **DELFIN** for a new copy.

The technical details contained in this manual are the property of **DELFIN** and should be deemed of a confidential nature.

Even partial reproduction of the graphic project, the text and the illustrations is legally forbidden.

Some details shown in the illustrations in this manual may be different from those of your vacuum cleaner. Some component parts may have been removed for greater clarity.

For easier reference, this manual is split into sections, identifiable by specific graphic symbols.

The subjects dealt with in this manual are those expressly required by "**Machine Directive 2006/42/CE**" and the technical details shown are those provided by the manufacturer at the time of compilation. For ATEX Vacuums, the reference directive is the 2014/34/EU.

This manual must be kept in a place accessible to all the personnel charged with operating and servicing the vacuum cleaner.

In case of any doubts, always immediately phone the **After-Sales Service**.

The competent Law Court for all disputes is that of TURIN (Italy).

TECHNICAL SERVICE

Our engineers are available to help you in case any problem occurs.

Please call +39 011. 800550

The manual must be kept with the vacuum cleaner in case of resale!



Information section

1.1 Identification of main parts - 1 -

1.2 Accessories provided - 3 -

1.3 Identification details of manufacturer - 6 -

1.4 Marking plate - 6 -

1.5 Intended uses..... - 7 -

1.6 Allowed environmental conditions - 7 -

1.7 Storage..... - 7 -

1.8 Scrapping - 7 -

1.9 Technical details..... - 8 -

1.10 Handling..... - 11 -

1.11 Warranty..... - 12 -

Safety section

2.1 Safety details..... - 13 -

2.2 Safety warnings..... - 14 -

2.3 Safety plates and symbols..... - 18 -

2.4 Outstanding risks - 19 -

2.5 Applied directives - 19 -

Operation section

3.1 Installation..... - 20 -

3.2 Description of controls - 23 -

3.3 Work cycle - 24 -

3.4 Releasing and removing the removable container/Removal and placing of the waste bag - 26 -

3.5 Filter cleaning system DUSTOP - 28 -

Maintenance section

4.1 Informative notes..... - 30 -

4.2 General safety warnings - 30 -

4.3 Maintenance operations - 31 -

4.4 Replacing the filters..... - 33 -

4.5 Troubleshooting - 35 -

Spare parts section

5.1 Recommended spare parts - 37 -



1.1 Identification of main parts



MTL202DS

- 1) ON/OFF switches
- 2) Motor head
- 3) Push handle
- 4) Dustop filter cleaning system
- 5) Filtering chamber
- 6) Suction point with cap
- 7) Fixed wheels
- 8) Castors
- 9) Removable vacuumed material container
- 10) Release fastener

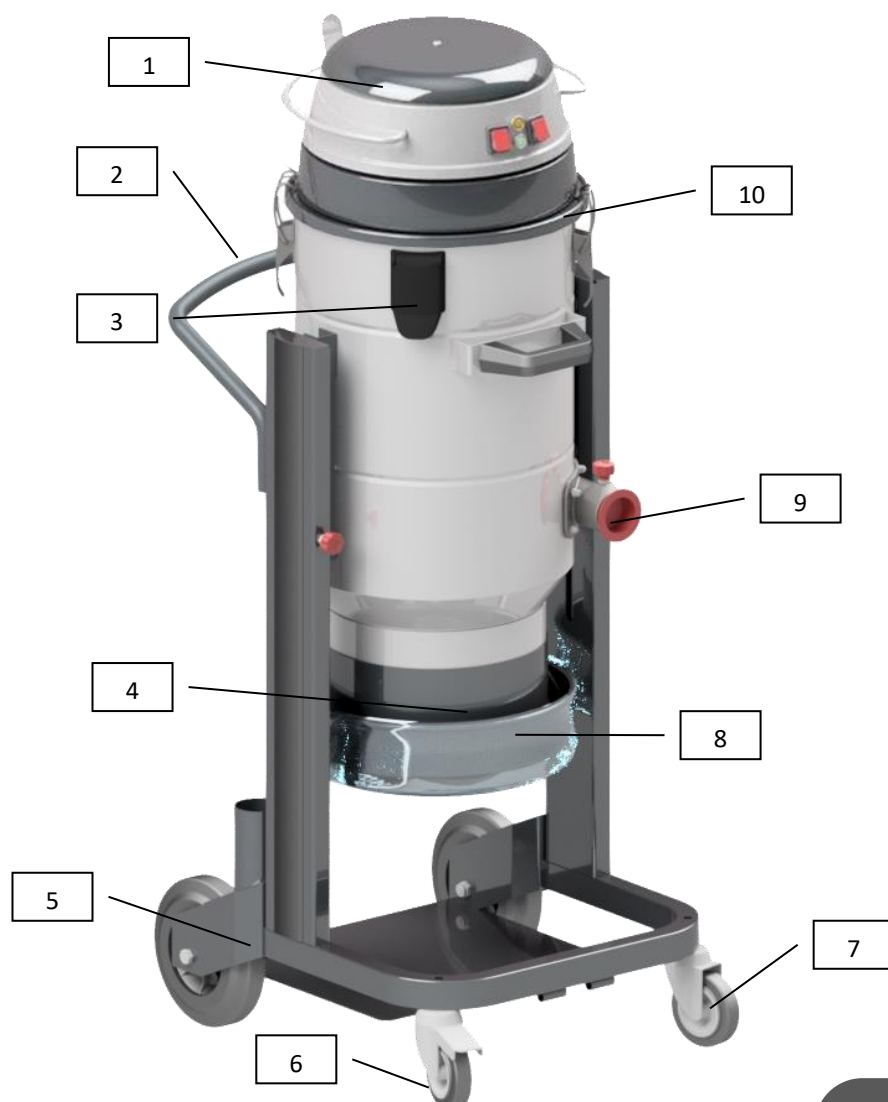

MTL202DSLP

- 1) Motor head
- 2) Push handle
- 3) Dustop filter cleaning system
- 4) Filtering chamber
- 5) Removable vacuumed material Longopac® container
- 6) Fixed wheels
- 7) Castors
- 8) Longopac® bag
- 9) Suction pipe coupling point
- 10) Release fastener



1.2 Accessories provided



FI.0232.0000

D. 340 H350 "M" CAT.FILTER CARTRIDGE FILTER FOR
MTL 202 DS PTFE
(only spare part)

Remark: these filters must be checked every six months. In case they are worn it will be necessary to replace them with new ones, to be requested as spare parts to ***DELFIN S.r.l.***

DELFINS.r.l. will accept no responsibility in case of use of ***NON-ORIGINAL*** filters.



ACCESSORI OPZIONALI/OPTIONAL ACCESSORIES	MODELLI/MODELS	
	MTL202DS	MTL202DSLP
EL/SYST - Remote control/avviamento locale remoto	✓	✓
PN/SYST - Pneumatic control/Avviamento locale pneumatico	✓	✓
M - Class M filter/Filtro classe M		
H- Absolute heap filter/ filtro assoluto Hepa	✓ FI.0013.0000	✓ FI.0013.0000
ANT M - Antistatic filter class M/filtro antistatico classe M	✓ FI.0233.0000	✓ FI.0233.0000
PTFE - PTFE coated filter class M/filtro PTFE classe M		
NOMEX- Heat resistant filter (up to 200°C)/Filtro resistente alte temperature (fino a 200°C)		
CA - Activated carbon filter - Filtro carboni attivi		
CA+H - Activated carbon filter and absolute filter/ filtro carboni attivi con filtro assoluto		
X - Stainless steel tank/Contenitore Inox	✓	
XX - Stainless steel tank and filter chamber/ Contenitore e camera inox	✓	✓
XXX - Stainless steel tank, filter chamber, cover and frame in stainless steel AISI304/ Contenitore , camera filtrante e struttura Inox		
CHX - Stainless steel chassis/ Carrello Inox	✓	
CTX - Stainless steel sieve grid/Cestello grigliato Inox		
FLT- Floating device/Galleggiante		
MT - Earth grounding/Messa a terra	✓	✓
LONGOPAC - Longopac bagging system- Sistema insaccamento Longopac		
CIC - Cyclone for filter protection/Ciclone per protezione filtro		
SGB - Sieve grid basket/ Cestello grigliato		
CHASSIS-Chassis with castors and push handle/Carrello con ruote e manico di spinta		
HDX-Hardox abrasion plate/piastra Hardox		
IP - Internal polishing for filter chamber and tank/lucidatura a specchio interno per camera e contenitore		
BSK- Abs accessory basket and doublebend holder/cesta per accessori e clip per doppia curva		
GR/VA- sieve grid and discharge valve/Cestello grigliato e valvola di scarico		
PUMP- Electrical discharge pump/Pompa elettrica di scarico		



ACCESSORI OPZIONALI/OPTIONAL ACCESSORIES	MODELLI/MODELS	
	MTL202DS	MTL202DS
AUT/PUMP- Automatic discharge with pump/ scarico automatico con pompa a contenitore pieno		
C/INFORC- Fork lift intakes / Inforcabile con muletto		
SIL/SUP- Additional silencer/Silenziatore addizionale		
C/COMP- compressor installed on board/ con compressore installato a bordo		
LOC/REM- Remote control/ avviamento locale-remoto		
SP- single phase vacuum unit/unità aspirante monofase		
BAG- Dust bagging system/ Sistema insaccamento	✓	
SD- Sliding damper for Dustop/ Valvola a ghigliottina per sistema Dustop	✓	
DEPR - Pressure differential kit for use of disposable bag/ kit depressore sacchetto monouso		
PPL300-PPL oil filtration kit 300 micron/Kit filtro PPL olio 300 micron		
PPL100- PPL oil filtration kit 100 micron/kit filtro PPL olio 100 micron		
OWR - Oil and water proof cartridge/cartuccia idro-olio repellente		
OMK - Oil Mists filter kit/Kit filtro nebbie oleose		
PR.DIFF-pressure differential switch/Pressostato differenziale		
INVERTER- Equipped with inverter/Equipaggiato con inverter		
MANUAL / Manual shaker/scuotifiltro manuale		
SELF CLEAN- Filter shaker with push button/scuotifiltro con pulsante		
DUSTOP- Filter cleaning system using differential pressure/ Sistema di pulizia filtro tramite pressione differenziale		
AUT - Automatic filter shaking cleaning for pocket filter/Scuotifiltro automatico per filtro a tasche		
PN- Automatic pneumatic filter cleaning system/Sistema di pulizia automatico in controcorrente d'aria		



1.3 Identification details of manufacturer

Delfin S.r.l.

Strada della Merla, 49/a
10036 Settimo Torinese (TO) Italy
Tel. +39 011-8005500
Fax +39 011-8005506
www.delfinvacuums.it
delfin@delfinvacuums.it

1.4 Marking plate

In compliance with the **Machine Directive 2006/42/CE** on vacuum cleaners, the machine is fitted with **CE** plates.

When contacting the manufacturer or dealer, always quote the details shown on the vacuum cleaner plate.

	Strada della Merla 49/a I-10036 Settimo Torinese (TO) - ITALY Ph. +39 011 800 55 00 F. +39 011 800 55 06 delfin@delfinvacuums.it www.delfinvacuums.it	
MOD. <input type="text"/>	S/N <input type="text"/>	
DESC. <input type="text"/>	YEAR <input type="text"/>	
50 Hz <input type="text"/>	FILTER <input type="text"/>	
60 Hz <input type="text"/>	<input type="text"/>	
www.delfinvacuums.it	Made in Italy	



1.5 *Intended uses*

These specific vacuum cleaner models have been designed, built and protected for vacuuming dusts and solid materials only, using special filters.

For ATEX vacuums, antistatic filters are used according to ATEX Directive 2014/34/EU.

Warning!

Always use specific filters for the type of dust or materials to be vacuumed.

Any other use is considered ***IMPROPER***.

The vacuum cleaner is in any case intended for professional industrial use.

1.6 *Allowed environmental conditions*

To ensure the correct operation of the vacuum cleaner, this must be positioned protected against atmospheric agents (rain, hail, snow, fog, dusts in suspension, etc.) with an environmental running temperature between 5°C and 45°C and relative humidity not above 70%.

The work environment must be clean, well-enough lit and devoid of explosive atmosphere.

1.7 *Storage*

Remove the filter and clean it, empty the container (in case of Longopac vacuums: replace the bag) and store the vacuum cleaner in a place protected against atmospheric agents with a temperature between 0°C and 40°C. Cover with a nylon sheet to prevent accumulation of dust.

1.8 *Scrapping*

In case of scrapping, all the component parts of the vacuum cleaner will have to be disposed of through adequate disposal channels in accordance with applicable legislation.

Before scrapping, all plastic and rubber parts will have to be separated from the electrical material. Parts made of plastic, aluminium and steel only may be recycled if collected by special centres.



1.9 Technical details

<i>Model</i>		MTL202DS	MTL202DS 2kW 115V	MTL202DSL ^P	MTL202DSL ^P 2kW 115V
<i>Power</i>	<i>kW</i>	2,3	2	2,3	2
<i>Voltage</i>	<i>Volts</i>	230 /50-60 Hz	115/50-60Hz	230/50-60 Hz	115/50-60Hz
<i>Max. vacuums rate</i>	<i>mm H₂O</i>	2.500	2.250	2.500	2.250
<i>Max. air flow rate</i>	<i>m³/h</i>	360	350	360	350
<i>Noise level (*)</i>	<i>dB (A)</i>	76	76	76	76
<i>Filter type</i>		Polyester cat. "M"	Polyester cat. "M"	Polyester cat. "M"	Polyester cat. "M"
<i>Filter surface</i>	<i>cm²</i>	30.000	30.000	30.000	30.000
<i>Capacity</i>	<i>lt</i>	20	20	<i>Longopac</i>	<i>Longopac</i>
<i>Suction inlet</i>	<i>∅</i>	50	50	50	50
<i>Dimensions</i>	<i>cm.</i>	59 x 48 x 110	59 x 48 x 110	50 x 48 x 125	50 x 48 x 125



<i>Model</i>		MTL202DSL ^P 2kW 230V	MTL202DSL ^P 1 MOT	MTL202DS 1,5kW 115V
<i>Power</i>	<i>kW</i>	2 (2x1000)	1,15	1,5 (2X750W)
<i>Voltage</i>	<i>Volts</i>	230/ 50-60 Hz	230/50-60Hz	115
<i>Max. vacuums rate</i>	<i>mm H₂O</i>	2.350	2.500	2.050
<i>Max. air flow rate</i>	<i>m³/h</i>	360	180	300
<i>Noise level (*)</i>	<i>dB (A)</i>	75	74	76
<i>Filter type</i>		Polyester cat. "M"	Polyester cat. "M"	Polyester cat. "M"
<i>Filter surface</i>	<i>cm²</i>	30.000	30.000	30.000
<i>Capacity</i>	<i>lt</i>	<i>Longopac</i>	<i>Longopac</i>	20
<i>Suction inlet</i>	<i>∅</i>	50	50	50
<i>Dimensions</i>	<i>cm.</i>	59 x 48 x 110	59 x 48 x 110	59 x 48 x 110



() Noise level*

Noise level readings were taken in accordance with the provisions of *Machine Directive 2006/42/CE* standards.

Sound tests performed on this specific vacuum cleaner model have been taken from a distance of 1 meter and from a height of 1,60 meters, showing an acoustic pressure no higher than the one indicates in the table.

The vibrations transmitted by the machine are lower than 2,5 m²/s.

Attention!

Pursuant to articles L.D. 81/08, workers exposed to sound pressure levels above 85 dB (A) must be protected by special individual protection devices.

It is therefore necessary, if such working conditions exist, to provide workers with such approved individual protection devices and to inform them of the risks relating to noise exposure.



1.10 Handling

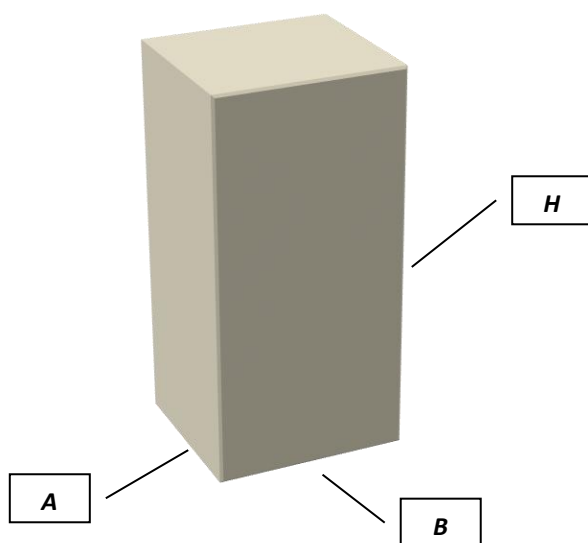

	<i>A</i> (cm)	<i>B</i> (cm)	<i>H</i> (cm)	<i>Weight</i> (package included) Kg
<i>MTL202DS</i>	60	70	130	44
<i>MTL202DSLP</i>	57	67	150	54

The machine is supplied in a strong cardboard box secured with straps.

Transport the package using a fork-lift truck of adequate lifting capacity and make sure it is stable and that weight is properly distributed on the forks.

Before starting to move, make sure the transit area is free and that there are no moving objects on the packaging.

During movement, keep the load low for greater stability and safety.

When starting up the vacuum cleaner, move this by means of the wheels supplied.

The appliance must never be moved using fork-lift trucks or other equipment that lifts it off the floor.

If for any reason the need arises to lift and transport the vacuum cleaner, this operation must be performed under the responsibility of the user. The user is therefore invited to secure the load as he best thinks fit to ensure the operation is performed in total safety.



1.11 Warranty

DELFIN guarantees this vacuum cleaner model for a period of 24 months from the date of purchase indicated on the tax document at the time of delivery of the vacuum cleaner by the seller.

The warranty shall be invalidated in the event of the vacuum cleaner having been repaired by unauthorised third parties or of equipment or accessories being used that have not been supplied by **DELFIN** or which have not been recommended or approved by **DELFIN** or whose serial number has been removed or altered during the warranty period.

DELFIN undertakes to repair or replace, free of charge, those parts which, during the warranty period show manufacturing faults. Repairs shall be made in the **DELFIN** facilities only or in a **Technical Assistance Centre** indicated by us and machines shall be sent to us carriage free (transport costs to be paid by the user, unless otherwise agreed).

The warranty does not cover any cleaning of working parts.

Faults not directly attributable to materials or manufacture shall be examined only in our facility or in a **Technical Assistance Centre** indicated by us. If claims appear unjustified, all the costs relating to repair and/or replacement of parts shall be charged to the buyer.

The purchase tax document shall be shown to the technical personnel making the repairs and must accompany the vacuum cleaner dispatched for repair.

The warranty does not cover: accidental damage, caused by transport or carelessness or inadequate treatment, or improper use not in compliance with the instructions in the instruction manual, or in any case by occurrences not dependent on normal operation or use of the vacuum cleaner. **DELFIN** declines all responsibility for any damage to persons or things caused by bad or improper use of the vacuum cleaner.

All disputes shall be referred to the Law Court of Turin (Italy).

The manufacturer declines all liability in the following cases:

- *Failure to send the warranty Certificate*
- *Failure to follow the instructions*
- *Use of non-original spare parts*
- *Failure to service the machine properly*



2.1 Safety details

The person in charge of safety shall be responsible for informing workers about the risks associated with vacuum cleaner operation.

The obligation also exists of training workers so they are able to protect themselves and others.

Failure to observe basic safety regulations and Warnings could cause accidents during vacuum cleaner operation, maintenance and repair. Accidents can often be avoided by recognising potentially dangerous situations before these occur. Operators should be aware of potential hazards and be trained and skilled enough. They should also have the tools necessary to perform these duties properly.

DELFIN shall under no circumstances be deemed liable for accidents or damage caused by use of the vacuum cleaner by personnel not properly trained or who use it in an improper manner, as well as by even partial failure to comply with the safety regulations and intervention procedures indicated in this manual.

The safety Warnings and warning notices are indicated in this manual and on the product.

Unless these hazard messages are heeded, the operator could become involved in accidents with serious consequences for him/herself and for other people.

The safety messages are highlighted by the following symbols:

<p>Attention! <i>Unless these messages are heeded, operator injuries could occur.</i></p>
--

<p>Warning! <i>Unless these messages are heeded, vacuum cleaner damage could occur.</i></p>
--

DELFIN cannot foresee all possible circumstances capable of representing a potential hazard. The warnings in this manual and on the products should not therefore be deemed exhaustive. In the event of tools, procedures, work or machining methods being used that are not explicitly recommended by **DELFIN**, make sure no hazards exist for operators and others.

<p><u>Only ever use original DELFIN spare parts.</u></p> <p>DELFIN declines all liability in the event of non-original spare parts being used.</p>
--



2.2 Safety warnings

Attention!

The following indications are, by themselves, not enough to fully protect against all the hazards that could arise during vacuum cleaner operation. These will have to be integrated with common sense and the experience of the operator, both of which are crucial factors for preventing accidents. Each section of this manual lists further specific safety warnings for the various operations.

Maintenance jobs must always be performed with the power plug detached from the power point.

The employer must inform and train the user according to the provisions of applicable laws.

Before using the machine, prepare and train yourself by reading this manual carefully. Use of the machine by untrained and unauthorised persons is forbidden.

Using the machine to vacuum toxic substances is forbidden unless this has been equipped with special filters required for the specific type of dusts. Such filters must be explicitly requested by you.

If the machine is used to vacuum toxic-harmful substances, the container must be emptied and the filters cleaned using adequate individual protection devices, selected according to the type of substances to be vacuumed.

Do not vacuum flammable materials or substances or which could cause explosions (fuels, solvents, etc.). To vacuum such materials, the machine must be built with Anti-explosion Motor and Electric System and this must be requested by you explicitly.

Do not vacuum corrosive substances unless the machine is equipped with containers suitable for this purpose (*Stainless-steel AISI 304*).

Use of the machine without the supplied filters is not recommended.

If the filters are correctly fitted, the machine will not eject any objects.

Never rest miscellaneous materials on the horizontal protection guard.

The machine casing containing moving parts must not be removed by the user.

When using the machine, mind other people, especially children.

Use the machine cautiously on slopes and ramps.

Do not change direction on gradients.

Make sure the parked machine remains stable by operating the braked wheel.

During cleaning operations, maintenance jobs or when changing parts, the starter switch must be off and the machine must be disconnected from the power mains by removing the cable from the socket.

Only skilled persons should carry out repairs.



During use, mind the power supply cables and avoid crushing or pulling these.

Periodically check the mains power cable to ensure this is not damaged.

In the event of the cable being damaged, the machine must not be used.

In the event of the cable, plugs or couplings being replaced, make sure these are protected against water spray and check mechanical strength.

Never pull the machine by means of the power cable and the vacuum pipe.

Motor brushes and burnt-out fuses must be replaced by **DELFIN** or authorised dealers. Always use original spare parts.

The user is responsible for disposing of vacuumed substances in accordance with applicable laws.

After 10 years of use, we recommend sending the machine for a complete overhaul to **DELFIN S.r.l.**

The machine is supplied with: instruction manual, Exploded Spare Parts drawing, Test Sheet, Warranty Slip, Approval Certificate.

In the event of Customers fitting a tool to the machine not supplied by **DELFIN**, make sure the safety conditions required by **Machine Directive 2006/42/CE** are complied with and in any event, **DELFIN** is unable to accept liability for any problems arising from use of such tool.

The vacuum cleaner must not be operated in a corrosive or explosive environment.

Always make sure the vacuum cleaner is free of all foreign materials such as debris, oil, equipment and other objects that could affect operation and cause injury to persons.

Avoid using flammable or toxic solvents such as petrol, benzene, ether and alcohol for cleaning.

Avoid prolonged contact with solvents and inhaling their vapours. Avoid use close to open flames or sources of heat.

Never use the vacuum cleaner without the filter.

Do not vacuum lit cigarette ends. The filter could be damaged.

Do not vacuum petrol or flammable liquids in general.

Make sure all the guards and protection devices are in place and that all the safety devices are in place and working properly.

Do not wear loose or hanging clothing such as ties, scarves or torn garments that could become trapped and be sucked up by the cleaner.

Do not open the vacuum container with the machine running.

The manual should always be kept handy for reference so the operating cycle can be checked every time there are doubts. In the event of this manual being lost or damaged, ask **DELFIN** for a new copy.



Structural damage and improper alterations or repairs could change the protection capacity of the vacuum

cleaner and therefore cancel this certification.

Any alterations to the appliance must only be made by *DELFIN* engineers.

During maintenance jobs, affix a notice to the appliance indicating **"MACHINE BEING SERVICED, DO NOT START"**.

Climbing on the cleaner is forbidden.

Never touch electric wires, switches, buttons, etc. with wet hands.

Before connecting to the power mains, make sure the power voltage and frequency are those shown on the machine plate.

Make power connections to a mains supply with efficient earth system.

In the event of an extension being used, make sure this is in perfect condition, marked *CE* and that the cross section of the cable is suitable for the vacuum cleaner power input.

When restoring original working conditions, the appointed personnel should make sure that at the end of the operating procedure, proper vacuum cleaner operation safety conditions are restored, especially the safety devices and the protective guards.

Only adult persons should use the vacuum cleaner.

During vacuuming operations, always brake the vacuum cleaner using the special revolving wheel lock.

In case of vacuums with grounding system, connect the grounding clamp with a conductive surface connected with the earth.

For ATEX Vacuums:

- Connect the grounding clamp with a conductive surface connected with the earth.
- Do not manumit the vacuum/pressure relief valve.
- All maintenance operations must be executed in non-classified atmosphere.
- Do not vacuum incandescent or burning material.
- The operator must always wear antistatic cloths and shoes. The floor of the area to be vacuumed must be antistatic.
- The opening of the dust collection container must be executed in non-classified atmosphere area, after having disconnected and unplugged the machine and only after 10 minutes from unplugging.



- It is prohibited to vacuum toxic substances unless the machine is provided with the necessary specific filters for the type of dust to be vacuumed. Such specific filters must be expressly required by the Customer for supply.
- Do not vacuum flammable or explosive substances gases or liquids (fuels, solvents etc.).
- Do not vacuum corrosive substances unless the machine is equipped with suitable containers (*Stainless-steel AISI 304*).
- Do not suck lighted cigarettes, cigarette stubs or incandescent materials.
- Do not vacuum sources of ignition.
- The supply cable tap must be correctly plug in the current outlet in **NON CLASSIFIED** atmosphere, or rather in a safety place.

For LONGOPAC Vacuums:

- If the machine is used to vacuum toxic-harmful substances, the Longopac® container must be emptied and the filters cleaned using adequate individual protection devices, selected according to the type of substances to be vacuumed.
- Do not open the vacuum Longopac® container with the machine running.



2.3 Safety plates and symbols

Plates are affixed to the vacuum cleaner showing safety symbols and/or messages.

Attention!

Make sure all the safety messages are legible.

Clean these with a cloth, soap and water. Do not use solvents, diesel fuel or petrol.

Replace the damaged plates with new ones supplied by DELFIN.

If a plate is affixed to a replaced part, make sure a new plate is affixed to the new part.

Attention!

Read the operator's and maintenance manual carefully before using the cleaner or doing any maintenance jobs.

IMPORTANT

***DO NOT BREATHE IN INFLAMMABLE AND/OR
EXPLOSIVE LIQUIDS OR POWDERS***

Warning!

Risk of crushing upper limbs while fitting and locking the material container (or material Longopac® container) on the vacuum cleaner.

Never place hands between the material container (or the material Longopac® container) and vacuum cleaner while locking.

Do not place hands on sides of container (or Longopac® container) near the guide pins while locking.

Perform the container (Longopac® container) locking operation by means of the levers located on the side, USING BOTH HANDS!



2.4 Outstanding risks

Careful analysis of risks performed by the manufacturer and stored in the technical file has made it possible to eliminate most of the risks associated with vacuum cleaner operation.

The manufacturer advises carefully following the instructions, procedures and advice contained in this manual as well as applicable safety regulations, including the use of the envisaged protection devices, both those integrated in the cleaner and individual.

Outstanding risks associated with the vacuum cleaner could be:

Risk of improper use in the presence of explosive and flammable substances.

The vacuum cleaner must not be used in environments containing substances in the form of liquids that could vaporise at room temperature and flammable dusts and gas.

Risks of operation in humid environments.

Keep to the limits shown in this manual at chap. 1.6 Allowed environmental conditions.

Risk of erroneous interpretation of the safety pictograms.

Having identified the various outstanding risks, the manufacturer has affixed to the cleaner a number of hazard labels in compliance with regulations relating to the graphic symbols to be used. The user must immediately replace any safety plates that become illegible due to wear or damage.

Attention!

Removing the safety plates on the vacuum cleaner is strictly forbidden. The manufacturer declines all liability in relation to vacuum cleaner safety in the event of failure to comply with the above indications.

2.5 Applied directives

The following directives apply to the vacuum cleaner described in this manual:

- *2006/42/CE Machine Directive*
- *2014/30/EU Electromagnetic compatibility directive (**)*
- *2014/35/EU Low-voltage directive (**)*
- *For ATEX Vacuums: 2014/34/EU ATEX Directive*

*(**) For Air Series Vacuums, do not refer to this Directive.*



3.1 Installation

Warning!

Before installing the vacuum cleaner, carefully make a sight check to pinpoint any damage suffered during transport.

In the event of any component parts being damaged, do not proceed with installation. Notify the manufacturer and reach an agreement on how to proceed.

The vacuum cleaner already features a suction filter.

Fit the accessory required for the type of vacuuming operation on the opposite end of the hose.

Note: No standard accessories (reducers, hoses, nozzles) are included with the vacuum; accessories must be specified and ordered separately.









Contact your dealer for information relating to the different types of *optional accessories* available for this specific vacuum cleaner model.

Fit the supplied pipe on the connector.





Make sure the power supply corresponds to the voltage and frequency indicated on the vacuum cleaner plate. For AIR SERIE vacuums, please check the vacuum's operating values

STANDARD	 <p>Strada della Merla 49/a I-10036 Settimo Torinese (TO) - ITALY Ph. +39 011 800 55 00 F. +39 011 800 55 06 delfin@delfinvacuums.it www.delfinvacuums.it</p>  MOD. <input type="text"/> S/N <input type="text"/> DESC. <input type="text"/> YEAR <input type="text"/> 50 Hz <input type="text"/> FILTER <input type="checkbox"/> 60 Hz <input type="text"/> <input type="checkbox"/> www.delfinvacuums.it Made in Italy
SERIE AIR	 <p>Strada della Merla 49/a I-10036 Settimo Torinese (TO) - ITALY Ph. +39 011 800 55 00 F. +39 011 800 55 06 delfin@delfinvacuums.it www.delfinvacuums.it</p>  MOD. <input type="text"/> S/N <input type="text"/> FILTER <input type="checkbox"/> DESC. <input type="text"/> YEAR <input type="text"/> OPERATING PRESSURE <input type="text"/> AIR SUPPLY <input type="text"/> MAX VACUUM <input type="text"/> MAX AIR FLOW <input type="text"/> www.delfinvacuums.it Made in Italy
ATEX	  MOD. <input type="text"/> S/N <input type="text"/>  <input type="text"/>  <input type="text"/>

Warning!
Do not fit the plug in the power socket with wet hands.

In the event of an extension being used, make sure this is in perfect condition, in compliance with **CE** standards and with cable cross section suitable for the power input of the vacuum cleaner.



LONGOPAC)

First of all pull the red handle on the right side of the vacuum cleaner and unlock the sliding system.



The vacuum cleaner will raise automatically, however it is possible to use the superior handle to guide the movement with a balanced force.

Pull the vacuum cleaner until the lock will have reached its position.

If the operator notes that the movement become difficult, remove the side cover, loosen the screws and if necessary put some grease on the sliding system.



3.2 Description of controls



- 1) **STOP/START** switch
- 2) CLOGGED FILTER – Orange indicator light
- 3) Green **POWER ON** indicator light



3.3 Work cycle

Warning!

Before fitting the plug, make sure the power voltage corresponds to that on the CE marking plate.

- Make sure the power plug is correctly fitted in the power socket.
- Make sure the flexible hose is properly fitted and locked in the vacuum pipe union.
- Make sure the power cable and any extension used are integral and in perfect condition.
- Block the vacuum cleaner by means of the retainer provided.



- Grip one end of the flexible hose complete with selected accessory.
- Press the **Start** button and start vacuuming.
- To stop the vacuum cleaner, press the **Stop** button

Warning!

Before switching the vacuum cleaner back on, make sure the motors have come to a complete halt.

- After finishing work, disconnect the vacuum cleaner from the power socket.



To move the vacuum cleaner, use the large handle.



Warning!

The vacuum can be moved only on flat ground!

If the vacuum is moved on inclined grounds, you can risk to lose the control, because of the weight and to damage persons or things.

Warning!

During vacuuming, avoid rolling up or bending the flexible hose.



3.4 Releasing and removing the removable container/Removal and placing of the waste bag

MTL202DS

Stop the vacuum motors by pressing the relevant **STOP** buttons.

Warning!
Disconnect the plug from the power socket.

- Lift the lever located in the bottom part of the cleaner to release and remove the container.



- Remove the container



Empty the contents of the container into a special waste disposal container in accordance with laws applicable in the country where the vacuum cleaner is used.

Warning!
While performing these operations, it is best to wear a dust protection mask.

To prevent having to use a dust protection mask and for greater convenience, before starting vacuuming operations, it is best to fit a nylon bag inside the container and to fasten this in place with the special accessory available on request.

Warning!
Perform the container release operation by means of the levers located on the sides or on the handle with BOTH HANDS!
Danger of crushing upper limbs when fitting and locking the container on the vacuum cleaner.



MTL202DSL

Stop the vacuum motors by pressing the relevant **STOP** buttons.

Warning!
Disconnect the plug from the power socket.

- Use two clamps to fasten the collection bag at two points (about 3 – 5 cm. from each other), just below the filter chamber.
- Cut off the bag in the position between the two clamps.
- Remove the lower part of the bag.



- Pull down a length of new bag from the chamber, until it reaches the bottom support plate



Attention!
Used bags should be disposed of into a special waste disposal container, in accordance with laws applicable in the country where the vacuum cleaner is used.



3.5 Filter cleaning system DUSTOP

When the orange indicator light is on, or the suction efficiency has lowered, or after having vacuumed a considerable quantity of material, a filter cleaning cycle is necessary. The filter cleaning system is best operated every time before use and after prolonged operation.

- First of all, disconnect all the accessories (flex hose, hose connector, etc.) from the vacuum cleaner.



- Turn on both motors and then proceed to close the suction inlet with the cap attached to the suction inlet itself, assuring that there is no air flow through the filtering chamber.





- Open the flap as indicated in the picture below allowing the air to flow into the filtering chamber thus providing a counter air flow that passes through the filter. Repeat this operation for at least 5 times.



- Once the cleaning process has finished, remove the cap from the suction inlet and connect the accessories to continue the vacuum process.
- If the orange light indicator is still on, repeat the filter cleaning process. If after this second cleaning process the orange light is still on, replace the filter with a new one.

Warning!
During vacuuming, avoid rolling up or twisting the flexible hose

Warning!
Never use the machine with the filter blocked.



4.1 Informative notes

This section describes the control and special maintenance operations crucial for keeping the vacuum cleaner in perfect working condition.

FOR ATEX VACUUMS

Attention!

All the transport and handling's operations described in this section must be done in NOT CLASSIFIED zone, which means in an area with non potentially explosive atmosphere.

Any other jobs which might be necessary to eliminate operating faults must be expressly authorised by the manufacturer. In such cases, always notify the identification details of the cleaner.

In the case of major repairs, it is best to contact an authorised dealer, whose skilled personnel, backed by all the technological experience relating to the original factory construction methods, are always available and ready to promptly intervene.

4.2 General safety warnings

Maintenance jobs must always be performed by skilled technicians, trained to carry out their specific jobs. In the case of this machine, these are:

- Mechanical maintenance
- Electrical maintenance (***)

The Safety Manager has the precise duty of determining the professional capacities and skills of such persons.

Before doing any maintenance job, the safety manager must:

- Make sure there are no unauthorised persons in the work area.
- Make sure the necessary tools are on hand and that these are in good condition.
- Make sure that lighting is adequate and, if necessary, provide 24-V portable lamps.
- Make sure the maintenance engineer is equipped with all approved individual protection devices needed for the specific operation (gloves, eyewear, shoes, etc.).
- Make sure the maintenance engineer has carefully read the instructions contained in this manual and knows how the vacuum cleaner works.

Before carrying out a maintenance job, the maintenance engineer must:

- Disconnect the plug from the power socket. (***)
- For ATEX Vacuums: Execute such operation in **NON CLASSIFIED** atmosphere, which means in an area with non potentially explosive atmosphere.



Work done on motors or other electrical component parts must only be performed by a specifically trained electrician, authorised by the Safety Manager.

Always use tools that are in perfect condition and specifically made for the operation to be done. The use of unsuitable tools or tools not in good condition could cause serious damage.

*(***) For Air Series Vacuums, do not consider.*

4.3 Maintenance operations

Attention!

All the described operations must be done with the plug disconnected from the power socket. Before starting any maintenance or cleaning job, always wear adequate protective clothing, eyewear and/or gloves according to the type of job to be done.

For smooth vacuum cleaner operation, a number of controls are best made periodically:

- Check to see whether the filter is worn or has become too permeable.
- Make sure the sealing gaskets of the motor head base, of the filter-holder ring and of the container are working efficiently.
- The electrical parts (plugs, switches, cables, etc.) must not be faulty.
- The screws and nuts must always be tight.
- Make sure the container is not overfull. This should be emptied when the vacuumed material has reached 3/4 of maximum capacity.
- Check the integrity of the flexible vacuum hose and accessories to be used.
- If the flexible hose is perforated, the power of the cleaner will be reduced and dust and liquids will leak into the environment.
- For vacuums with electric panel: A qualified operator must periodically verify the cables' tightening in the electric components of the electric board: with prolonged use of the vacuum, the vibrations can loosen the tightenings and cause important damages to components.
- For vacuums with compressor:

For maintenance operations of the compressor, see the specific manual.

However, it is necessary to check the oil level of the compressor periodically, the absence of oil in the compressor will damage it.



ATTENTION!

Periodically check the compressor's air filter integrity (1) and the shape of compressor's shelter.

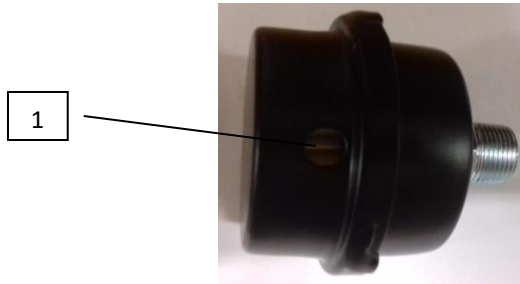

In case of shelter's damage, the filtration isn't guaranteed.

The blockage or not correct working of these components can make incorrect working of the compressor and oil's outflow.

Warning!

All maintenance and repair jobs must be performed directly by DELFIN or its authorised dealers.



4.4 Replacing the filters

To replace the filters, proceed as follows:

- Turn off the vacuum cleaner by pressing the motor **STOP** buttons.
- Disconnect the vacuum cleaner plug from the power socket.

Important!
Wear individual protection devices.

- Release the two retainers that hold the motor head in place. Lift the motor head and rest this on a flat surface being careful not to damage the power cable.





- Loosen the screws.



- Remove the filter.



Important!
All the material trapped by the filter and the filter itself must be disposed of through authorised channels in the country where the vacuum cleaner is used.



4.5 Troubleshooting

<i>Fault found</i>	<i>Possible fault</i>	<i>Recommended remedy</i>
<i>The cleaner fails to start</i>	No power	Check the power mains supply Check the integrity of the plug and power cable
	Thermal magnetic switch tripped	Reset the thermal magnetic switch
<i>Dust is leaking out</i>	Perforated vacuum pipe	Replace the pipe
	Perforated filter	Replace the filter
	Filter unsuitable for type of job	Fit a suitable filter for the type of material to be vacuumed
<i>The vacuum cleaner does not work as it should</i>	Pipe perforated or blocked	Check the pipe and, if necessary, replace it
	Container full	Empty container
	Filter blocked	Clean the filter and if necessary change it.
	Seals worn	Check the seals and, if necessary, replace it
	Air leak	Check for any air leaks out of closing fasteners, tightening screws, container or filter chamber
<i>Motor very noisy.</i>	<i>Contact DELFIN after-sales</i>	

Warning!
For any other problems, contact the DELFIN after-sales service.



Pump

<i>Fault found</i>	<i>Possible fault</i>	<i>Recommended remedy</i>
<i>Pump not operating motor fails to start</i>	No power	Power the machine
	Automatic switch tripped or fuse burnt out	Reset the switch or replace the fuses with other suitable ones.
	Overload switch tripped	Resets automatically after cooling in single-phase version
	Faulty condenser	Change the condenser
<i>Pump not operating motor starts</i>	Impeller blocked	Foreign bodies between the fixed and rotating parts of the pump
	Liquid level dropped and bottom valve no longer under water	Be careful, the mechanical seal could be damaged.
<i>Pump not operating motor starts</i>	Pump not filled with liquid or drained due to leaks	Be careful, the mechanical seal could be damaged
	Difference in pumping level above pump capacity or flow resistance too high during suction	Replace the suction pipe with one of bigger diameter. Reduce elbow bends to a minimum. Eliminate deposits.
<i>Pump operates at reduced flow rate</i>	Pump or pipe blockages	Clean or remove blockages
	Overload switch tripped	Pump not turning freely. Viscous liquid.



5.1 Recommended spare parts

<i>Code</i>	<i>Description</i>
<i>FI.0232.0000</i>	D340X350H "M" CARTRIDGE FILTER
<i>GI.0146.0000</i>	MTL 202 DS BASE PLATE GASKET
<i>GI.0140.0000</i>	10x22 ADHESIVE MOUSSE GASKET



DELFIN Srl

Strada della Merla, 49/a

10036 Settimo Torinese (TO) – Italy

Tel. 0039.011.8005500

Fax 0039.011.8005506